

# Solid MagiDrive Series

## MD40 Series

(CF40, 2.75" OD Flange)



The MD40 MagiDrive provides high torque rotation on a 70mm OD (2¾" OD CF) flange. The drive is ideally suited to applications such as the rotation of samples and small platens, where stability is key. The MD40 is also available in a hollow configuration.

### MD40 KEY ADVANTAGES

- » Magnetically-coupled fail-safe design
- » No bellows or dynamic seals
- » High torque rotation (9Nm)
- » Bakeable to 250°C
- » Zero backlash under low load
- » True UHV performance

The production-proven MagiDrive range of rotary feedthroughs enable rotation to be transferred into a vacuum system using a stiff high flux magnetic coupling. With no bellows, fluids or dynamic seals, the MagiDrive range offers reliable and totally leak-tight UHV operation.

### Example Dimensions (mm)

For comprehensive 2D drawings & 3D models please contact us.

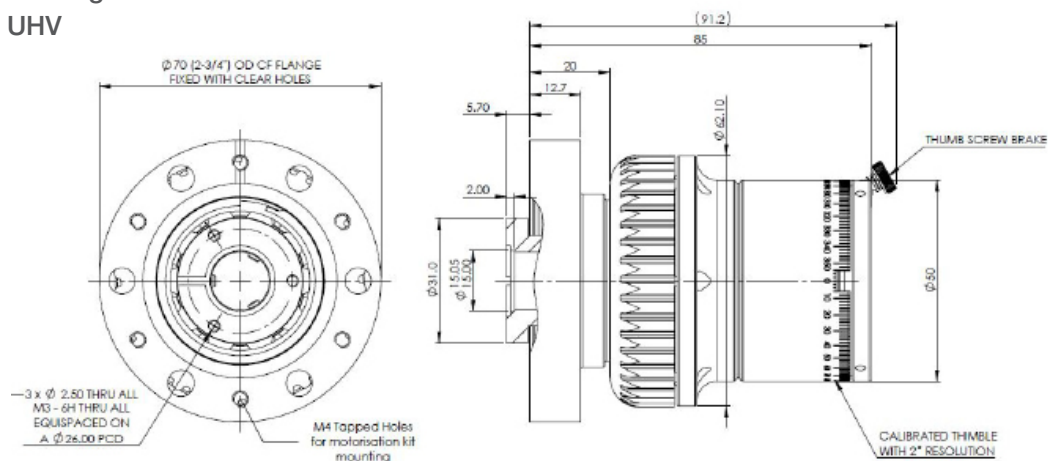

## MD40 Technical Data

SPECIFICATION	VALUE
System mounting flange size	FC38 (2 3/4") with clear holes
Rear Flange option	FC16 (1 1/3") with clear holes
Drive clear bore	14.5mm (rear flange option)
Magnetic breakaway torque	9Nm
Magnetic coupling stiffness	1.31 Nm/degree
Bakeout temperature	250°C with motor/pneumatic cylinder removed
Shaft options	spigot flange
Shaft radial runout at shaft attachment	0.01mm
Maximum radial load	2000N
Maximum axial load	142.5N
Calibrated thimble resolution	2°
Pulley - type and PCD	HTD profile 40 teeth 5mm pitch and 63.66 PCD
Pneumatic option - cylinder sweep	adjustable 30° to 170°
Pneumatic option - cylinder bore	30 mm
Pneumatic option - cylinder fitting	4mm tube push fit
Pneumatic option - cylinder switch	5-24V 2 wire reed switch
Pneumatic option - max rotation speed	0.2 seconds per 90° (dependant on load)
In line Stepper motor option	23 frame Nanotec AS5918S2804 3A / phase
Side mounted Stepper motor option	23 frame Nanotec AS5918S2804 3A / phase (Option 1) and 17 frame Nanotec AS4118L1804 1.8A / phase (Option 2-4)
Standard stepper option - motor wiring	M12 5 pin connector
Upgrade stepper motor option - switches	Omron slotted opto 24V PNP type. Wired to WD-S-004
In line Stepper motor max speed option 1, gear ratio, output torque & resolution per 1/2 step	500 rpm, 1:1, 0.7Nm and 0.9°
In line Stepper motor max speed option 2, gear ratio, output torque & resolution per 1/2 step	300 rpm, 5:1, 3.2Nm and 0.18°
In line Stepper motor max speed option 3, gear ratio, output torque & resolution per 1/2 step	150 rpm, 10:1, 6.4Nm and 0.09°
In line Stepper motor max speed option 4, gear ratio, output torque & resolution per 1/2 step	60 rpm, 25:1, 9Nm and 0.036°
Side mounted Stepper motor max speed option 1, output torque & resolution per 1/2 step	500 rpm, 2:1, 1.4Nm and 0.45°
Side mounted Stepper motor max speed option 2, output torque & resolution per 1/2 step	188 rpm, 8.3334:1, 1.9Nm and 0.108°
Side mounted Stepper motor max speed option 3, output torque & resolution per 1/2 step	54 rpm, 28.125:1, 5.8Nm and 0.032°
Side mounted Stepper motor max speed option 4, output torque & resolution per 1/2 step	38 rpm, 40:1, 8.4Nm and 0.023°
DC motor option	24V dc brushed geared motor
DC motor option - motor wiring	2 pin generic plug to diagram WD-010
In line and side mounted DC motor speed option 1	460 rpm, 0.5Nm and 230 rpm, 1.1Nm
In line and side mounted DC motor speed option 2	230 rpm, 1.1Nm and 115 rpm, 2.2Nm
In line and side mounted DC motor speed option 3	92 rpm, 2.5Nm and 46 rpm, 5Nm
In line and side mounted DC motor speed option 4	46 rpm, 5Nm and 23 rpm, 9Nm

### For more information:

**UHV Design Ltd**  
Judges House, Lewes Road,  
Laughton, East Sussex, BN8 6BN, UK  
T: +44(0)1323 811188  
E:sales@uhvdesign.com  
www.uhvdesign.com

### Официальный представитель:

**АО "ВАКУУМ.РУ"**  
Москва, Зеленоград  
тел: +7 (495) 139-65-69  
e-mail: info@vacuum.ru  
www.vacuum.ru