

Hollow MagiDrive Series

MD64LB(M) Series

(CF64, 4.5" OD Flange)



The MD64LB & MD64LBM MagiDrives provides high (8 Nm) or ultra-high (40 Nm) torque rotation through a high stiffness coupling with a large 48.5mm clear bore. This drive is ideally suited to platen rotation or robot type applications. The MD64LBM supplies higher torque with the same dimensions.

MD64LB(M) KEY ADVANTAGES

- » 48.5mm clear bore
- » High torque / stability
- » No bellows or dynamic seals
- » Bakeable to 250°C
- » Zero backlash under low load
- » True UHV performance

The production-proven MagiDrive range of rotary feedthroughs enable rotation to be transferred into a vacuum system using a stiff high flux magnetic coupling. With no bellows, fluids or dynamic seals, the MagiDrive range offers reliable and totally leak-tight UHV operation.

The four largest MagiDrives are available in a hollow configuration, terminating with a non-rotating CF flange at the rear. This allows services to be passed through the drive or alternatively, an additional MagiDrive to be mounted to the rear, providing a secondary axes of rotation. Up to four independent axes of rotation can be provided by combining the MD16, MD35H, MD64H and MD100H MagiDrives. This stacking capability is typically used to provide simple solutions to sophisticated manipulation requirements.

Example Dimensions (mm)

For comprehensive 2D drawings & 3D models please contact us.

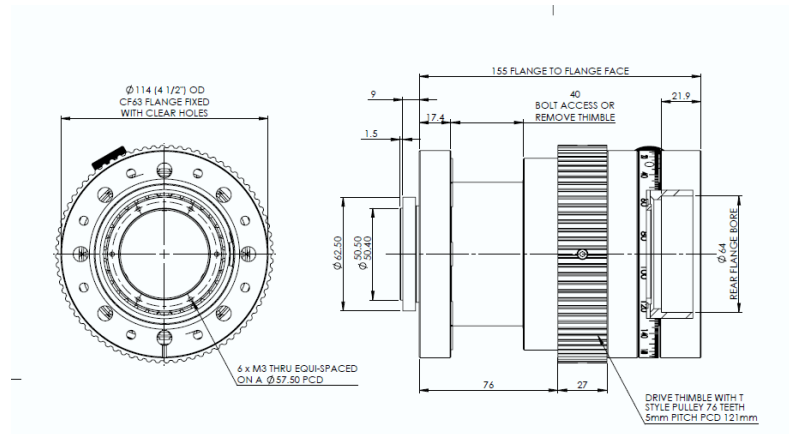

MD64LB Technical Data

SPECIFICATION	VALUE
System mounting flange size	FC64 (4 1/2") with clear holes
Rear Flange	Rotatable type FC64 (4 1/2") with tapped holes
Drive clear bore	48.5mm
Magnetic breakaway torque standard option	8Nm
Magnetic breakaway torque MD64LBM option	40Nm
Magnetic coupling stiffness standard option	1.7 Nm/degree
Magnetic coupling stiffness MD64LBM option	4.5 Nm/degree
Bakeout temperature	250 °C with motor removed
Shaft options	spigot flange
Shaft radial runout at shaft attachment	0.01mm
Maximum radial load	8300N
Maximum axial load	415N
Calibrated thimble resolution	1 degree
Pulley option - type and PCD	T profile 76 teeth 5mm pitch and 121 PCD
Stepper motor option	23 frame 8 wires 3A / phase
Standard stepper option	UTO motor 23HT18C230
Stepper motor maximum speed option 1, output torque, gear ratio and resolution per 1/2 step	150 rpm, 3.7Nm, 5:1 and 0.09 degrees
Stepper motor maximum speed option 2, output torque, gear ratio and resolution per 1/2 step	75 rpm, 7.3Nm, 10:1 and 0.045 degrees
Stepper motor maximum speed option 3, output torque, gear ratio and resolution per 1/2 step	30 rpm, 8 or 16.8Nm*, 25:1 and 0.018 degrees
Stepper motor maximum speed option 4, output torque, gear ratio and resolution per 1/2 step	15 rpm, 8 or 33.6Nm*, 50:1 and 0.009 degrees
DC motor option	24V dc brushed geared motor
DC motor option - motor wiring	2 pin generic plug to diagram WD-010
DC motor speed option 1 and output torque	245 rpm, 1.7Nm
DC motor speed option 2 and output torque	98 rpm, 4.3Nm
DC motor speed option 3 and output torque	49 rpm, 7.9Nm
DC motor speed option 4 and output torque	25 rpm, 10Nm

*MD64LBM option

For more information:

UHV Design Ltd

Judges House, Lewes Road,
Laughton, East Sussex, BN8 6BN, UK
T: +44(0)1323 811188
E:sales@uhvdesign.com
www.uhvdesign.com

Официальный представитель:

АО "ВАКУУМ.РУ"

Москва, Зеленоград
тел: +7 (495) 139-65-69
e-mail: info@vacuum.ru
www.vacuum.ru